

SPECIFICATIONS

Name & Model Number	Inada ROBO Chair HCP-D5A	
Power Supply	AC 120V	
Power Consumption	190W	
Power Frequency	60Hz	
Rated Time	30 minutes	
Upper Body	Kneading Speed	6 levels, from minimum 15 times/minute to maximum 40 times/minute
	Tapping Speed	4 levels, from minimum 300 times/minute to maximum 650 times/minute
	Roller Width	3 levels (Narrow, Medium, and Wide)
	Vertical Speed	Approx. 20 seconds /lap
	Back Stroke Range	Approx. 25 inches (in partial roller massage program, approx. 6 inches)
Pre-set Programs	Healthcare Programs: 5 types, Voice Massage Programs: 2 types (with Automatic Shiatsu Point Locator Function)	
Manual Selection Mode	20 types (some include Automatic Shiatsu Point Locator Function)	
Vibrating Function	2 types: Foot and Back Toggles between 2 levels of intensity for each location	
Air Massage	Air pressure approx. 32kPa	
Auto Timer	Approx. 15 minutes (Healthcare Programs vary in duration)	
Footrest Adjustment Range	Approx. 11.4 inches (with automatic Foot Slide adjustment function)	
Reclining Angle	Approx. 120° to 170° from floor level continuous motion (Automatic reclining)	
Chair Dimensions	Approx. 34 x 52 (80) x 45 (33) inches Numbers in () represent dimensions when fully reclined and with footrest flat	
Weight	Approx. 265 lbs. (Chair body: approx. 201 lbs., Footrest: approx. 55 lbs., Lower Arm units: approx. 9 lbs.)	
Outer Covering	Synthetic leather	
Accessories	Remote Control Stand, Power Cord, L-shaped Wrench, Shiatsu Foot Pad, Buffer Pad (Thick)	

FAMILY

inada ROBO chair

HCP-D5A

Thank you for purchasing the Inada ROBO Chair.
We hope the inada ROBO chair will be a valued partner in your daily health maintenance for many years to come.

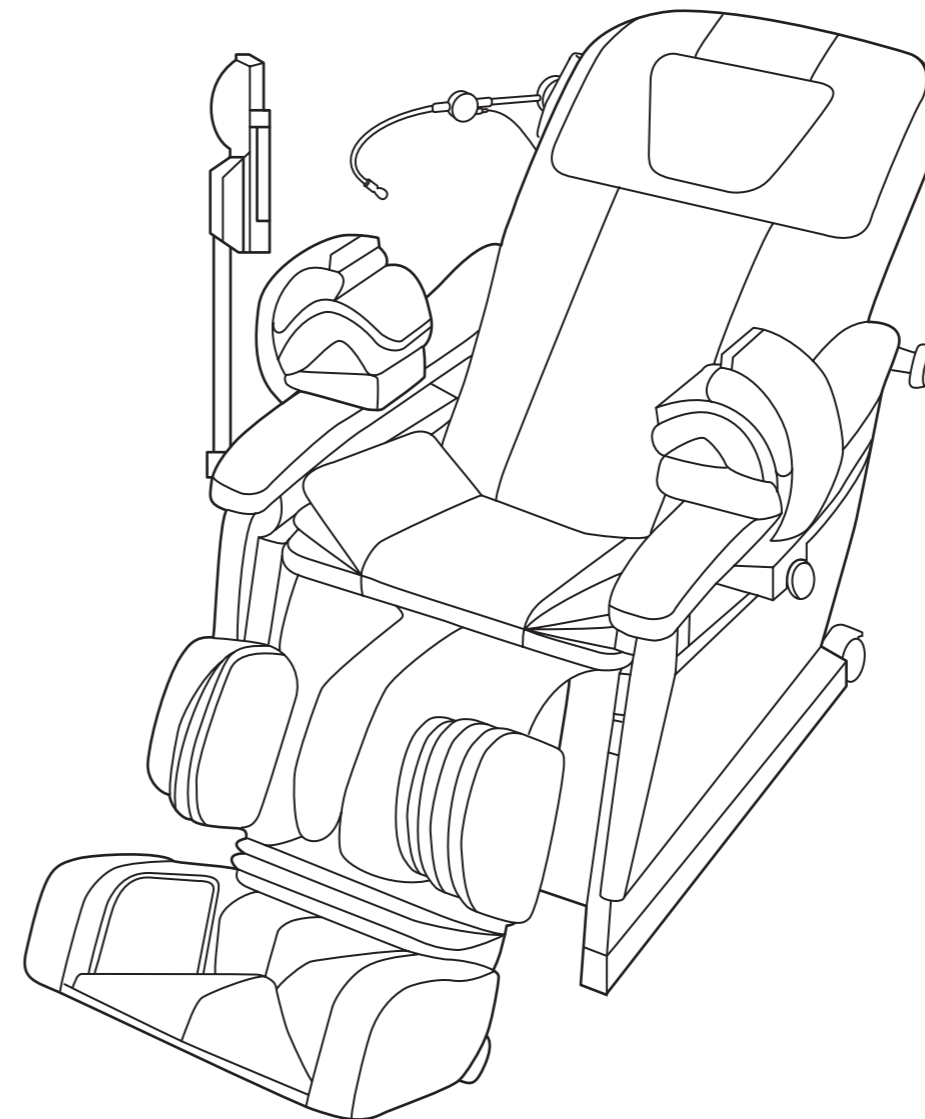

CONTENTS

- SAFETY PRECAUTIONS.....1
- MAIN FEATURES & BENEFITS ...4
- COMPONENTS & DESCRIPTION ...5
- BEFORE USE9
- POSITION ADJUSTMENT.....12
- AFTER USE.....14
- MASSAGE PROGRAMS & SELECTION...15
- MANUAL SELECTION MODE17
- HEALTHCARE PROGRAMS21
- VOICE CONTROL OPERATION GUIDE....24
- TROUBLESHOOTING.....29
- FAQ32
- CARE & STORAGE33
- CUSTOMER SERVICE & WARRANTY ...34
- REGULAR MAINTENANCE FOR SAFETY ...34
- SPECIFICATIONS.....BACK COVER

FAMILY INADA INC.

US Headquarters: 7 West 56th Street, New York, NY 10019

Toll-free: 1-877-22-INADA (1-877-224-6232)

Technical assistance: 10:00 -17:00 (Eastern Standard Time) / Closed: Saturdays, Sundays, and Public Holidays

<http://www.inada-chair.com>

776392701

○Read this Operating Manual carefully before use for proper handling.
○Keep this manual nearby so that you can refer to it anytime.
○Be sure to check for warranty at the time of purchasing and keep it at hand together with this operating manual.
○This product is designed for home use. For other use like that of an institutional nature, contact the vendor directly.

Operating Manual
Warranty card provided separately









SAFETY PRECAUTIONS

Be sure that you have read these SAFETY PRECAUTIONS thoroughly before using your Inada ROBO Chair for the first time. The Operating Manual contains important information about how to use the chair safely and correctly, avoiding possible damage to property or injury to persons using the chair and others. The symbols shown below are used throughout the Operating Manual to highlight important safety instructions. Please adhere to all precautions. Descriptions of each chair component can be found on pages 5-8.

Display Warnings



 Warning	This action could result in serious injury or death.	 Caution	This action could result in personal injury or damage to property.
--	--	--	--

Types of Symbols and Description





 Warning or caution	 Prohibited	 Do not disassemble	 Do not touch	 Do not use in or near water such as in a bathroom
	 Required action	 Electrical grounding	 Unplug the chair	

Remember to keep this Operating Manual in an easily accessible place.

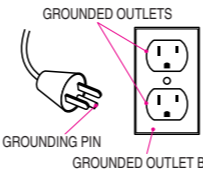

Safety Precautions: Installation

 Caution	 Do not install the chair in an area of high humidity such as a bathroom or sauna. →Could result in injury or electric shock.	 Do not use the chair outdoors.
 Required Action	Only install on a flat, level surface. →Chair could tip over accidentally if placed on an uneven surface.	

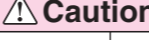

Safety Precautions: Before Use

 Warning	<ul style="list-style-type: none"> Space Requirements This product must be grounded. If it should malfunction or breakdown, grounding provides a path of least resistance for electric current in order to reduce the risk of electric shock. This product is equipped with a cord that has an equipment-grounding conductor and a grounding plug. The plug must be plugged into an appropriate outlet that is properly installed and grounded in accordance with all local codes and ordinances. Improper connection of the equipment-grounding conductor can result in the risk of electric shock. Check with a qualified electrician or serviceman if you are in doubt as to whether the product is properly grounded. Do not modify the plug provided with the product if it will not fit the outlet; have a proper outlet installed by a qualified electrician. This product is for use on a nominal AC 120V circuit and has a grounding plug that looks like the plug illustrated in the figure to the right. Make sure that the product is connected to an outlet having the same configuration as the plug. No adapter should be used with this product. 	
 Prohibited	<ul style="list-style-type: none"> The following persons must not use this massage chair: <ul style="list-style-type: none"> Persons who have been instructed by a doctor to avoid massage therapy. Ex. Thrombosis, severe aneurism, acute varicosity, or dermatitis and/or skin infection including inflammation of the hypodermis. Persons with suspected acute neck sprain (whiplash injury). 	
 Required Action	<ul style="list-style-type: none"> Persons with any of the following conditions should seek medical advice before using the chair. <ul style="list-style-type: none"> Serious heart conditions Sensory impairment caused by serious peripheral circulatory disorders due to diabetes and other diseases Osteoporosis, spinal fractures, acute pain and/or symptoms thereof Persons being treated for personal injuries High fever (100°F or higher) Ex. Strong acute inflammation illness caused by fatigue, chills, blood pressure fluctuation, or asthenia Persons in the early stages of pregnancy, or immediately after giving birth Persons who have electronic medical device(s) easily susceptible to electromagnetic interference Ex. pacemaker Abnormal or curved spine Persons planning to use the chair for treatment or for rehabilitation purposes Persons with malignant tumor(s) Persons under bed rest orders Persons with acute gastro-intestinal complaints or ailments such as gastritis, enteritis, or hepatitis Persons under a doctor's care, or those experiencing unusual physical discomfort Joint dysfunction due to rheumatism, gout, or other diseases Persons with symptoms such as qualm, dizziness, or tinnitus Inflammation due to sprain or torn muscles Persons who are unable to communicate, and persons who are physically challenged 	
 Prohibited	<ul style="list-style-type: none"> Do not use the chair with anything other than an AC 120 V power source. →May result in fire or electric shock. Do not use with any type of transformer device. →May result in injury or electric shock. Do not use if the power cord or plug(s) is damaged, or if the wall outlet is loose. →May result in electric shock, short circuit, or combustion. Before each use, check for holes or tears in the chair covering (lift the back pad to check the seat back). Also, check other parts for tearing. Stop using the chair immediately if you find even the smallest tear. Unplug the chair and contact the vendor for assistance. →Using the chair with holes or tears in the covering could result in injury or electric shock. 	

Safety Precautions: Before Use

 Caution	<ul style="list-style-type: none"> Make sure that the main POWER switch on the chair is set to OFF before plugging the power cord into the wall outlet. →May result in injury or electric shock. Make sure that the plugs on the power cord are inserted fully into the cord connector and the wall outlet. →May result in electric shock, short circuit, or combustion. Before using the chair for the first time, turn on all the power switches in order as indicated in this manual to check that the chair is operating properly. Before using, raise the reclining seat to its fully upright position. Then recline the seat back slowly to the most comfortable position, remembering to start off with a lighter massage. →Starting with a deep massage can result in injury. Elderly people and persons with weak bones should be especially careful when selecting massage intensity. When sitting down in the chair, do so slowly, ensuring that the spinal rollers are in the correct position at either side of the spine. The backbone should lie comfortably between the rollers without having to turn or twist the body. Do not sit, stand, or lean on the footrest unless you are sitting in the chair or getting up from the chair. →Personal injury or damage to the chair may result if the chair tips over. If you have not used this chair for a period of time, reread this Operating Manual to ensure correct usage.
 Required Action	<ul style="list-style-type: none"> Do not use the chair in any way not prescribed by the Operating Manual. Do not use the chair together with any other therapeutic device or with an electric blanket. →May result in injury or have a negative effect on health. Do not move the chair while someone is in it. →Accident or injury may result if the chair tips over.
 Prohibited	<ul style="list-style-type: none"> Do not use the chair in any way not prescribed by the Operating Manual. Do not use the chair together with any other therapeutic device or with an electric blanket. →May result in injury or have a negative effect on health. Do not move the chair while someone is in it. →Accident or injury may result if the chair tips over.

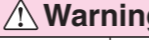
Safety Precautions: During Use



 Warning	<ul style="list-style-type: none"> Do not wrap the power cord or the remote control cord around the chair, or place the chair on top of either cord. Do not scratch, tear, treat, unduly twist, stretch, or bend the power cord or the remote control cord. →Cord may fray or tear, resulting in fire or electric shock. Do not spill or drop water on the chair or the remote control. →May result in electric shock, short circuit, or combustion. Children should not use the chair. It is advisable to keep children and pets away from the chair (especially behind the reclining seat back or under the seat or footrest). →May result in accident or injury. Do not use if the chair covering is torn. Unplug the power cord from the wall outlet. →May result in injury, accident, or electric shock. Contact the vendor for repairs. Do not place fingers or objects between the footrest units, footrest and chair, or under the lower arm units. Do not release hands suddenly while lifting the footrest manually. Do not sit on or get out of chair with the footrest raised.
 Prohibited	<ul style="list-style-type: none"> Do not use the chair while the body is wet, or with wet hands. →May result in injury or electric shock. Be sure that there is nobody (especially children), no pet or object around this chair before reclining the seat back or lowering the footrest. Be careful not to catch any part of the body or object behind it when reclining the seat back. Be careful not to get hands, feet, or objects caught in between the footrest units when activating the foot slide function. →May result in accident or injury.
 Required Action	<ul style="list-style-type: none"> Do not use the chair while the body is wet, or with wet hands. →May result in injury or electric shock. Be sure that there is nobody (especially children), no pet or object around this chair before reclining the seat back or lowering the footrest. Be careful not to catch any part of the body or object behind it when reclining the seat back. Be careful not to get hands, feet, or objects caught in between the footrest units when activating the foot slide function. →May result in accident or injury.

Caution



 Prohibited	<ul style="list-style-type: none"> Do not use the chair unclothed. Do not use the chair for purposes other than massage, or other than the ordinary uses of a chair. →May result in accident or injury. Do not use the chair to massage the head, chest, stomach, and/or joints (knees, elbows). Do not place hands, feet, or arms in between the rollers. →May result in nausea or injury. Place a soft towel behind your neck if you want to avoid intense stimulation of the area. Do not place hands or feet into the roller tracks, into the space between the seat back and the seat or into the moving parts. Do not sit wearing hard objects like hair accessories. →May result in personal injury. Do not place anything other than legs and feet on the footrest. →May result in personal injury. Do not use the lower arm units for any part of the body other than the forearms. →May result in personal injury. Do not operate the massage chair or leave it operating when there is no one in it. →May result in accident or injury.
---	--

SAFETY PRECAUTIONS



Safety Precautions: During Use

⚠ Caution	
 Required Action	<ul style="list-style-type: none"> ● In an emergency, or if there is any sudden malfunction, push the STOP button on the remote control to make the chair stop immediately. ● If you begin to experience marked pain or other unusual physical discomfort while using the chair, seek medical advice immediately and discontinue use of the chair. ● If you feel the massaging is too strong, reduce the stimulation according to this Operating Manual. If this solution does not work, stop using and contact the vendor. <ul style="list-style-type: none"> → May result in injury if you continue use with high stimulation under such circumstances. ● Make sure to keep the back pad in place during massage. Do not use the chair without the back pad. <ul style="list-style-type: none"> → May result in personal injury. ● Do not fall asleep in the chair during massage. <ul style="list-style-type: none"> → May result in personal injury. ● Keep massage sessions to no more than 15 minutes in length. Limit focused massage of any particular area on the body to no more than 5 minutes. <ul style="list-style-type: none"> → Continual use for extended periods of time can result in over-stimulation, which could cause the opposite of the desired effect, or even injury. Aim at no more than 30 minutes total massage time per day. ● If your leg or foot comes out of the footrest during leg or foot massage, do not try to force it back in. <ul style="list-style-type: none"> → Undue force on the chair may damage the unit. ● If your arm comes out of the lower arm units during lower arm massage, do not try to force it back in. <ul style="list-style-type: none"> → Undue force on the chair may damage the unit.
 Unplug	<ul style="list-style-type: none"> ● If there is a power outage or the possibility of a power outage, stop the chair immediately and turn the main POWER switch to OFF. Unplug the chair from the wall outlet. <ul style="list-style-type: none"> → Accident or injury may result if the chair is still in operating mode when the power resumes. ● If there is a threat of lightning, stop the chair immediately and turn the main POWER switch to OFF. Unplug the chair from the wall outlet. ● If the chair does not start, or if there is any type of malfunction, to prevent accidents it is best to stop the chair immediately and turn the main POWER switch to OFF. Unplug the chair from the wall outlet. Contact the vendor for assistance regarding repairs or maintenance. <ul style="list-style-type: none"> → Electric shock or fire caused by a short circuit may result if the chair is left plugged in under such circumstances.

Safety Precautions: After Use or When Not in Use

⚠ Caution	
 Required Action	<ul style="list-style-type: none"> ● Make sure to turn the main POWER switch to OFF after every use and to unplug the chair from the wall outlet. <ul style="list-style-type: none"> → Accident or injury may result if children or pets try to play with the chair. ● Be sure to return the reclining seat back to the upright position and lower the footrest completely after using the chair. ● Wipe the chair off after every use, and store your chair in a place free of excess humidity. ● Do not place any object on the seat, reclining seat back, footrest, or lower arm units.
 Unplug	<ul style="list-style-type: none"> ● Do not pull on the power cord to unplug the chair from the wall outlet; make sure to grasp the plug firmly when unplugging. <ul style="list-style-type: none"> → May result in electric shock or shortcircuit, which could in turn result in fire. ● When cleaning or caring for the chair, make sure to unplug the chair from the wall outlet first. Do not touch the power cord with wet hands. ● If you will not be using the chair for some time, make sure to unplug it from the wall outlet. <ul style="list-style-type: none"> → Dust and moisture can cause electrical insulation to deteriorate, resulting in possible electric shock, short circuit, or fire.

Other Safety Precautions

⚠ Warning	
 Prohibited	<ul style="list-style-type: none"> ● Do not stand on the chair. Do not sit on any part of the chair other than the seat. <ul style="list-style-type: none"> → Personal injury or damage to the chair may result if the chair tips over. ● Do not stand on the control box and/or place objects on it.
 Do Not Disassemble	<ul style="list-style-type: none"> ● Do not remodel the chair. Anyone other than an authorized serviceperson must not repair or disassemble. <ul style="list-style-type: none"> → May result in fire, electric shock, or injury. Contact the vendor for repairs.
⚠ Caution	
 Required Action	<ul style="list-style-type: none"> ● If you lend, sell, or otherwise transfer the chair to another party, make sure to include this Operating Manual.

MAIN FEATURES & BENEFITS

FEATURES

From palm to sole Fullbody Massage Function

The ideal relaxation, realized by all of our available technology.

Since the lower arm units move according to the seat back reclining, you can always be sure to get treatment on your arms while in a comfortable position. Enjoy an identical experience to that of a human massage on the back, buttocks, and calves, owing to our unique and wide variety of massaging techniques. The foot unit will simultaneously follow the reclining motion even when reclining at various angles to insure a comfortable massage.

Optic sensors provide for Automatic Shiatsu Point Locator Function

Automatically locates shiatsu points which vary from person to person. This allows for an effective massage that tailors itself to your size and shape.

Easy to read message guide Remote Control Display Panel

The remote control features a clear, easy to read display panel that enables you to monitor your massage. The display guides you through each step of your massage, displaying information about each massage action.

Vibration Massage Function

Vibration mechanisms are located in the seat, footrest (foot unit), and chair back.

The soothing vibrations make for a relaxing massage.

Easy to adjust to the most comfortable position Automatic Reclining Function

The seat back can be reclined to any angle between approx. 120° and 170°. The footrest can be raised to an approx. 90° angle. Both can be easily adjusted to find the most comfortable position for you.

Voice Control

Simple operations can be activated with previously inputted keyword. Also, two additional massage programs are available only through voice control.

With ultimate technology Various Course Functions

5 healthcare programs (auto) and manual selection mode can be selected to satisfy your particular needs.

Standard Remote Control Stand

A standard remote control stand is available which accommodates the remote control.

Foot massage unit stays on the soles of your feet Foot Slide Sensors

The footrest activates whenever you choose to recline the seat back. After reclining, the footrest length is adjusted automatically to provide a calf or foot massage according to your leg length.

BENEFITS

As a therapeutic massage device, the Inada ROBO Chair provides the following benefits:

- Relaxes muscles
- Relieves minor muscle aches and pains

COMPONENTS & FUNCTIONS

CHAIR

COMPONENTS & FUNCTIONS

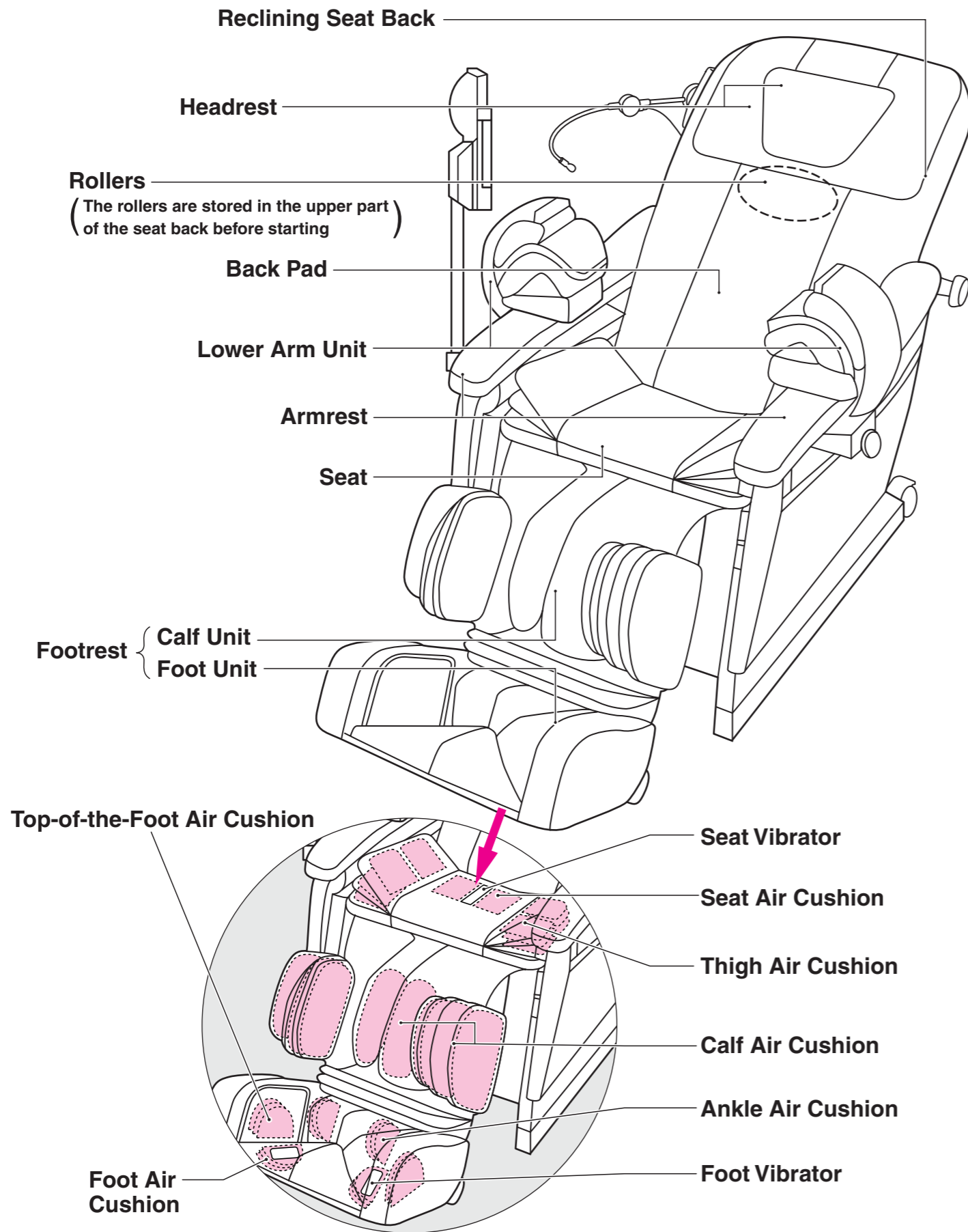

COMPONENTS & FUNCTIONS

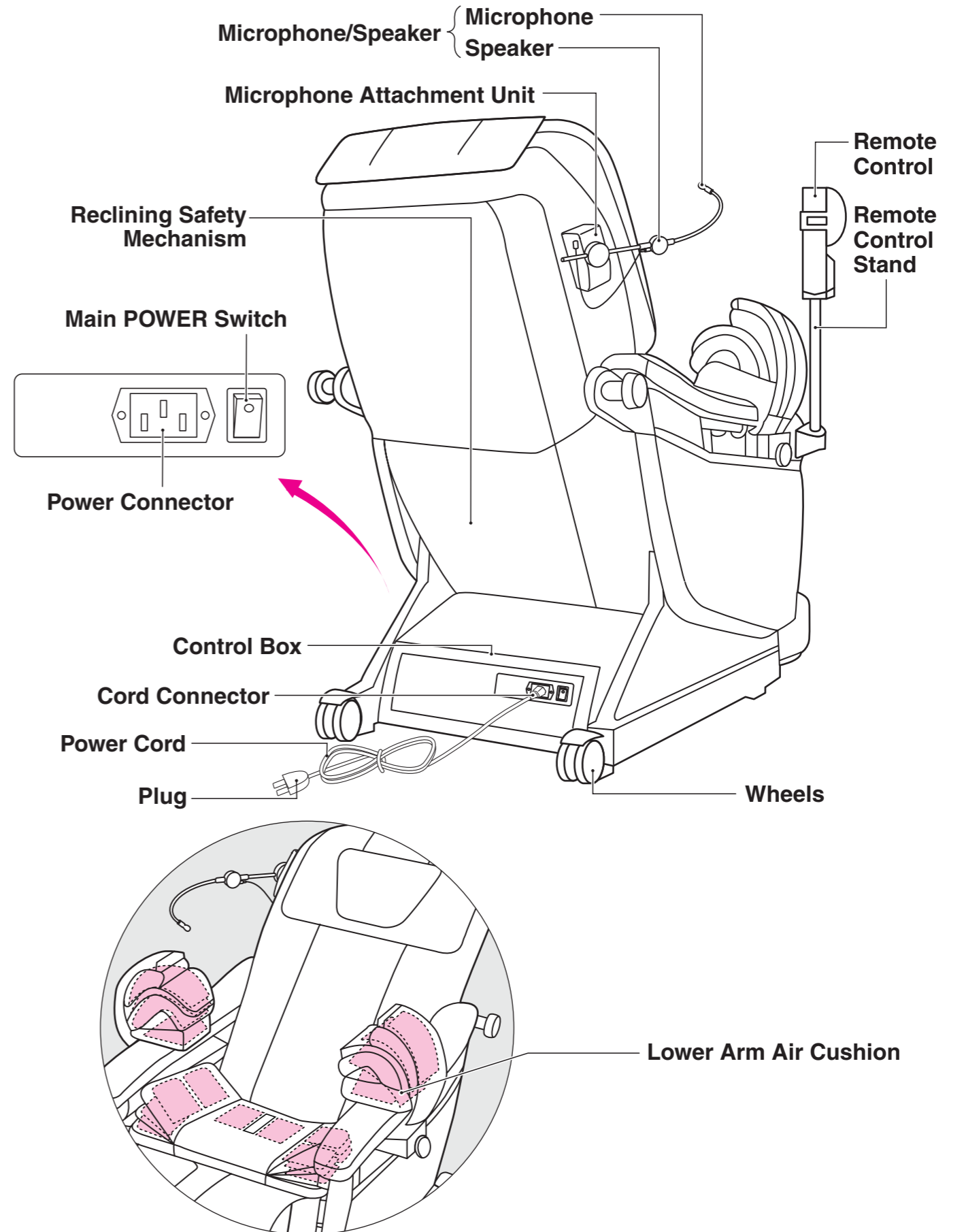

COMPONENTS & DESCRIPTION

REMOTE CONTROL

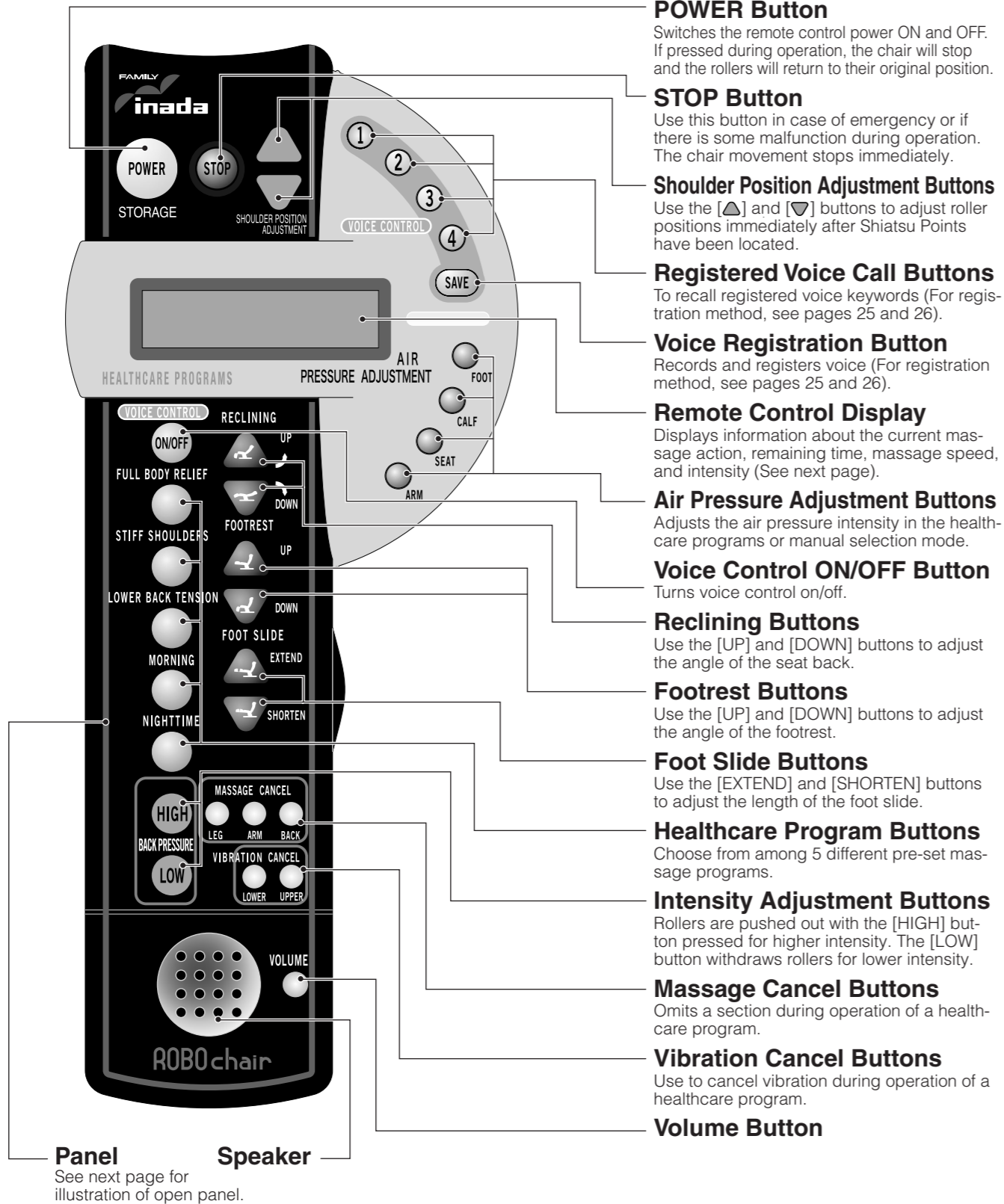

POWER Button
Switches the remote control power ON and OFF. If pressed during operation, the chair will stop and the rollers will return to their original position.

STOP Button
Use this button in case of emergency or if there is some malfunction during operation. The chair movement stops immediately.

Shoulder Position Adjustment Buttons
Use the [▲] and [▼] buttons to adjust roller positions immediately after Shiatsu Points have been located.

Registered Voice Call Buttons
To recall registered voice keywords (For registration method, see pages 25 and 26).

Voice Registration Button
Records and registers voice (For registration method, see pages 25 and 26).

Remote Control Display
Displays information about the current massage action, remaining time, massage speed, and intensity (See next page).

Air Pressure Adjustment Buttons
Adjusts the air pressure intensity in the healthcare programs or manual selection mode.

Voice Control ON/OFF Button
Turns voice control on/off.

Reclining Buttons
Use the [UP] and [DOWN] buttons to adjust the angle of the seat back.

Footrest Buttons
Use the [UP] and [DOWN] buttons to adjust the angle of the footrest.

Foot Slide Buttons
Use the [EXTEND] and [SHORTEN] buttons to adjust the length of the foot slide.

Healthcare Program Buttons
Choose from among 5 different pre-set massage programs.

Intensity Adjustment Buttons
Rollers are pushed out with the [HIGH] button pressed for higher intensity. The [LOW] button withdraws rollers for lower intensity.

Massage Cancel Buttons
Omits a section during operation of a healthcare program.

Vibration Cancel Buttons
Use to cancel vibration during operation of a healthcare program.

Volume Button

Warning

- Do not spill water and/or other liquids on the remote control.
- Do not handle the remote control with wet hands.
- Do not sit or step on the remote control. Do not drop the remote control. Do not pull the remote control cord forcibly.
- Do not use pointed or hard objects to push the buttons or display on the remote control.
→May result in damage to the remote control.

REMOTE CONTROL DISPLAY

Displays information about the current massage, time remaining, and speed and intensity settings, using both text and symbols. The text and symbols run from left to right on the display.

Example: During activation of Shiatsu Point Locator sensors, the following text is displayed:
"Locating Shiatsu Points..."

Remote Control Display



REMOTE CONTROL / INNER CONTROL PANEL

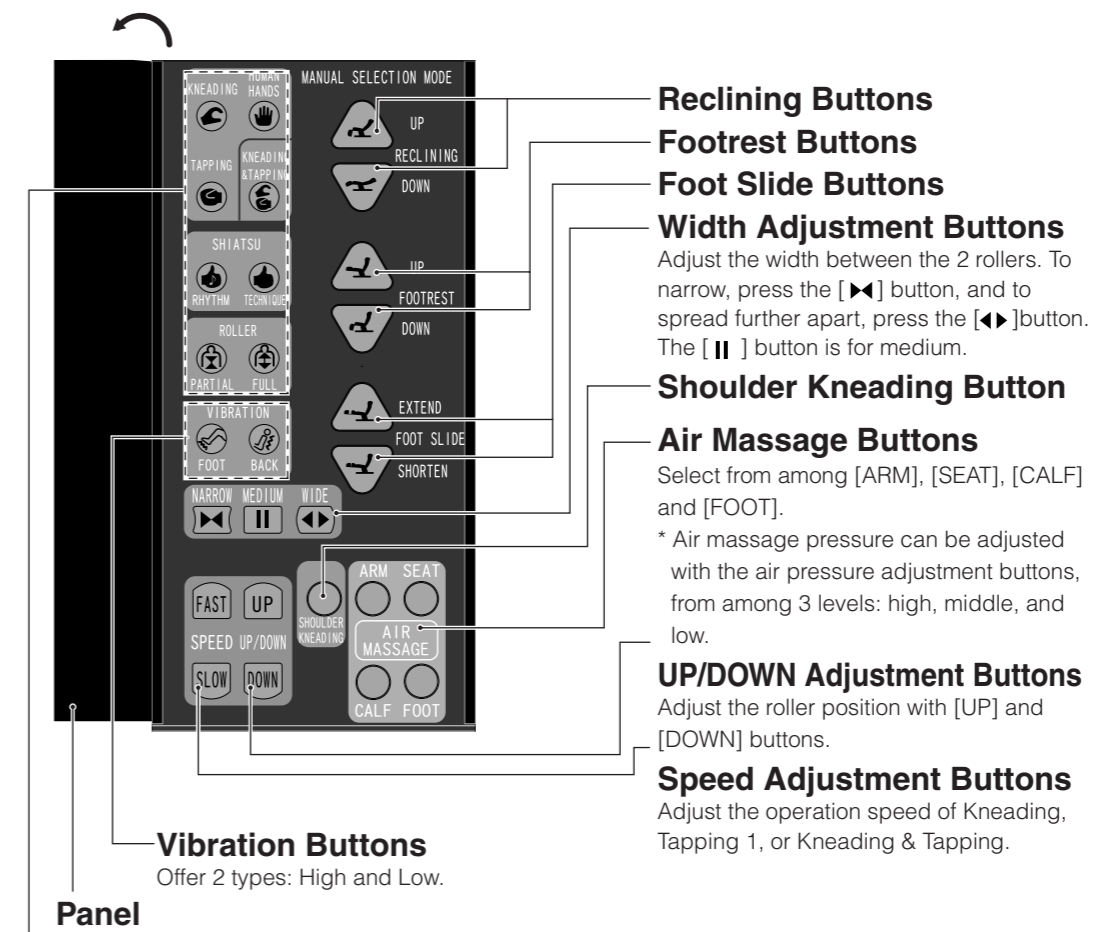

Reclining Buttons

Footrest Buttons

Foot Slide Buttons

Width Adjustment Buttons

Adjust the width between the 2 rollers. To narrow, press the [▶] button, and to spread further apart, press the [◀] button. The [||] button is for medium.

Shoulder Kneading Button

Air Massage Buttons

Select from among [ARM], [SEAT], [CALF] and [FOOT].

* Air massage pressure can be adjusted with the air pressure adjustment buttons, from among 3 levels: high, middle, and low.

UP/DOWN Adjustment Buttons

Adjust the roller position with [UP] and [DOWN] buttons.

Speed Adjustment Buttons

Adjust the operation speed of Kneading, Tapping 1, or Kneading & Tapping.

Vibration Buttons

Offer 2 types: High and Low.

Manual Selection Mode Buttons

Select from among Kneading, Human Hands, Tapping, Tapping/Kneading, Rhythm SHIATSU, Technique SHIATSU, Partial ROLLER, and Full ROLLER.

BEFORE USE

- This product is shipped with the reclining seat back in its fully reclined position and the lower arm units unattached. Be sure to raise the seat back to its fully upright position and set the lower arm units, referring to "How To Attach Lower Arm Units".
- Do not expose the chair to sudden bursts of heat. If the room where the chair is to be used is cold, turn the heat up slowly. If the chair is moved from a cold place into a heated room, wait one hour before using the chair.
 - Condensation could occur in moving parts of the chair, which may compromise performance.

Installation

Allow at least 20 inches clearance at the back and 16 inches in front of the chair lest the seat back should hit a wall or object while reclining.

⚠ Caution

- Do not use in areas of high humidity like bathrooms or saunas.
- Only install on a flat, level surface.
- Do not use in areas of high debris or dust content. Do not use where the ambient temperature is 100°F or more.
- Do not install the chair where it can come into contact with direct heat, such as direct sunlight or radiator.
- To avoid damaging floor surfaces and to cut down on the noise of the chair, it may be better to install the chair on a carpeted surface or to lay a piece of carpet under the chair (Do not use electric blanket).
- The chair is very heavy, so please be careful when unloading it so as not to damage floor surfaces.
- Install the chair at least 40 inches away from TVs, radios, and/or other audio or video equipment. Noise from these devices can cause problems.

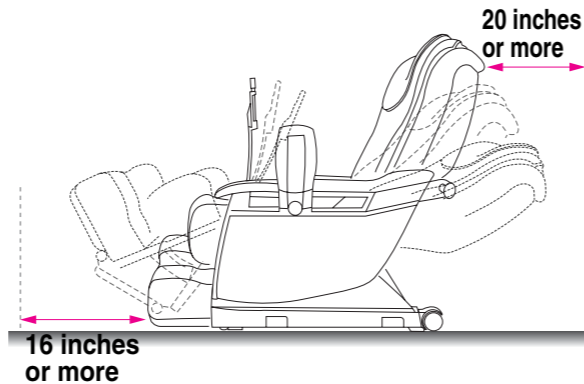

Main Power Connection

1. Plug the power cord into the connector outlet located at the back of the chair first. Then plug the other end into the wall outlet.

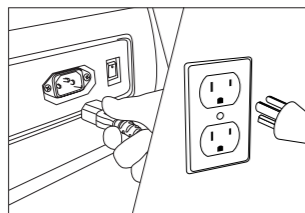

2. Turn on the main POWER switch on the back of the chair. A text message should appear on the remote control display screen.

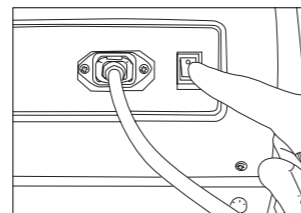

* If the rollers have stopped in mid-massage, turning the main POWER switch ON again will reset the rollers to the Starting Position (upper part of seat back). The chair will then turn itself off.

⚠ Caution

- Before plugging the power cord into the wall outlet, make sure that the main POWER switch is set to OFF.
- Make sure that the plugs on the power cord are inserted fully into the connector and outlet.
- Before using the chair for the first time, turn on all the power switches in order as indicated in this manual to check that the chair is operating properly.

How To Attach Remote Control Stand

1. Align the guide of the remote control stand to the armrest hole on the right of the chair and fix in place with the screw using the L-shaped wrench provided.
2. Place the remote control holder cap on until it clicks into place.

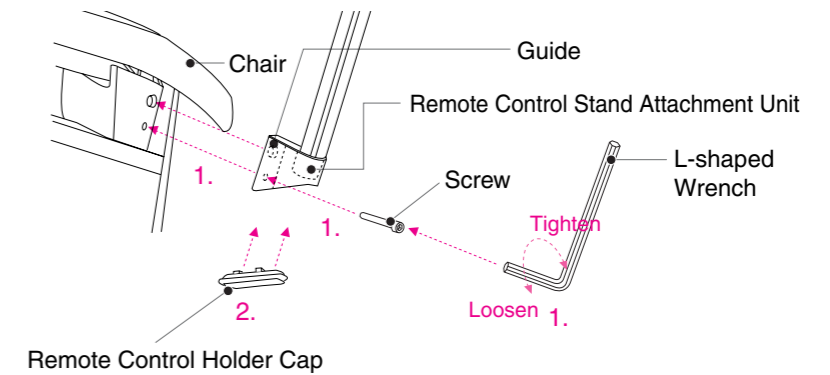

How To Attach Lower Arm Units

1. Align the slide guide of the lower arm units with the armrest attachment portion of the chair before inserting.
2. Fully tighten the fixing screw after the unit slide guide is in place.

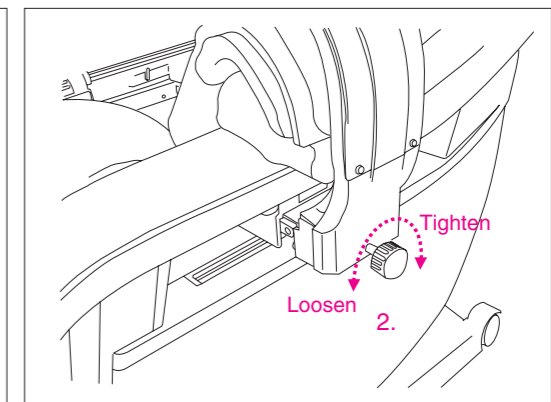
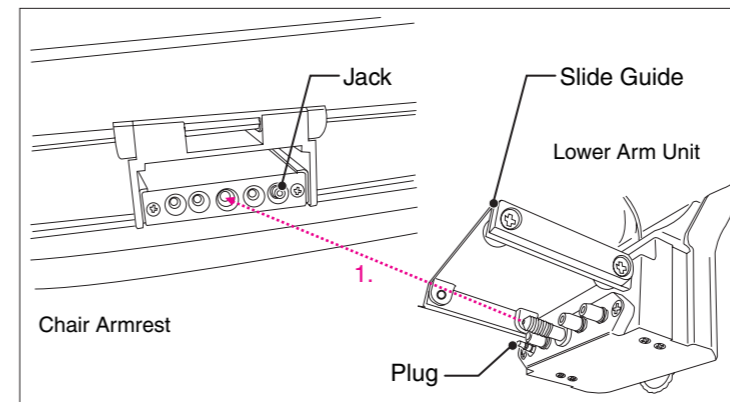

- Do not forcibly attach the lower arm units to the chair armrest. Insert the plug on the unit into the chair's jack slowly and steadily.

⚠ Caution

- The lower arm units could slip off during operation if the screw is not properly fixed. Be sure to tightly fix the screw.

How To Install Microphone/Speaker

1. Insert the microphone/speaker into attachment unit as illustrated.
2. Insert the microphone plug into the jack on the backside of the attachment unit. Place the cap on the end of the microphone/speaker.

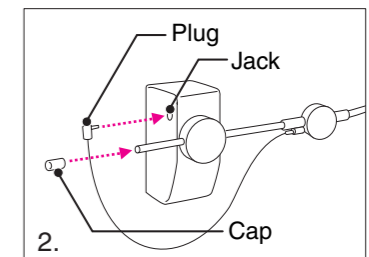
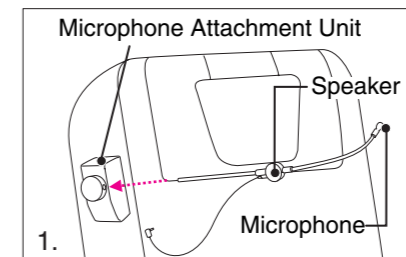

BEFORE USE

Checking Seat Cover

Lift the back pad up as shown in the illustration to make sure that there are no tears in the chair covering beneath it.

Warning

- Check for tearing on the chair by lifting up the back pad before use. Also, check the other parts. Stop using the chair immediately if you find even the smallest tear. Unplug the chair and contact the vendor for assistance.

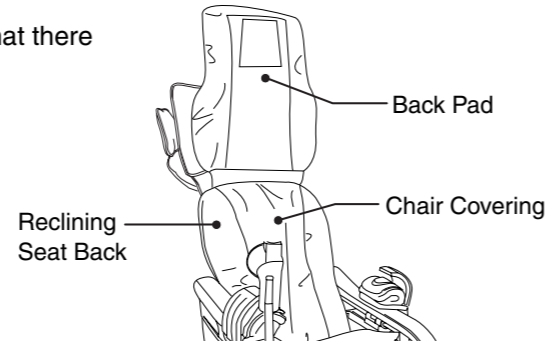

How To Move Chair

The chair is equipped with wheels that make it easy to move. First, raise the reclining seat back and turn main POWER OFF. Then, unplug the power cord from the outlet and lift the chair up with the tips of the armrests as is shown in the illustration on the right. Wheel in the desired direction with the front part lifted up.

Warning

- Do not move the chair while someone is in it.
- Be careful not to get feet caught underneath when moving the chair.

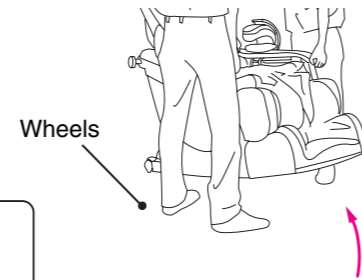

BEFORE USE

POSITION ADJUSTMENT

Voice Mark

There are several items in this manual headed by the **Voice** mark. These items can be operated with your voice when the voice control is on (See pages 24 to 28).

How To Sit

Make sure that the footrest is down and the microphone is positioned as is in the illustration on the right. The rollers are usually withdrawn at the upper part of the seat back spread to the right and left (Storage Position). For safety reasons, check the roller position. If they are in any position other than Storage Position, turn the main POWER switch on before sitting down to allow the rollers to return to Storage Position. Then, sit down slowly with your back centered on the seat back.

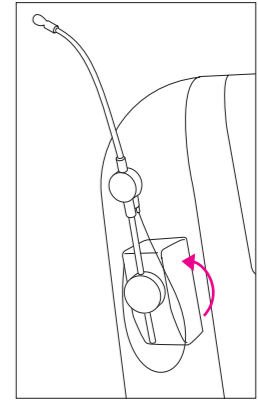

Caution

- Before using, raise the reclining seat back to its fully upright position. Then recline the seat back slowly to the most comfortable position, remembering to start off with a lighter massage.
- Do not sit down on the chair with the footrest raised. Any sudden heavy weight on the footrest could cause damage to the mechanism.

Voice How To Use Reclining Function

To raise the seat back

Press the [UP] button. Release when your desired angle is obtained. The seat back will end up in the chair's upright position if the reclining button is not released.

To lower the seat back

Press the [DOWN] button. Release when your desired angle is obtained. The seat back will end up in the chair's horizontal position if the reclining button is not released.

- The footrest moves accordingly with the seat back. When the reclining operation stops, the footrest stops as well. Then, the foot slide auto adjustment function activates to extend or shorten the foot slide to match leg length.
- If the reclining button is released, the foot slide auto adjustment function becomes active.
- If fine adjustment is needed to the foot slide length after auto adjustment, press either one of the foot slide buttons.
- If the main POWER switch is set to ON, you can adjust the reclining position.

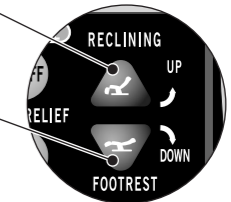

Warning

- Be sure that no one, especially children or pets, is in the way when lowering the seat back. Be careful that people and/or objects are not caught behind the seat back.

Voice How To Use Footrest

To raise the footrest

Press the [UP] button. The footrest is fixed in place when you release the button at the desired angle.

To lower the footrest

Press the [DOWN] button. The footrest is fixed in place when you release the button at the desired angle.

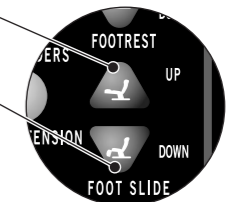

- When the footrest stops, the foot slide auto adjustment function activates to extend or shorten the foot slide to accommodate leg length.
- The foot slide auto adjustment function starts when the footrest button is released.
- If fine adjustment is needed to the foot slide length after auto adjustment, press either one of the foot slide buttons.
- Be sure that the main POWER switch at the back of the chair is set to ON before footrest position adjustment.

Warning

- Be sure that no one, especially children or pets, is in the way when lowering the footrest. Be careful that people and/or objects are not caught behind the seat back.
- Do not release hands suddenly while lifting footrest by hand.

Caution

- Do not place anything other than the legs and feet on the footrest.

POSITION ADJUSTMENT

POSITION ADJUSTMENT

Voice Foot Slide Automatic Adjusting Function

Foot Slide Sensors

Sensors are located in the ankle area to extend or shorten the length of the foot slide.

Place your ankles to fit the foot unit for accurate sensor reaction.

* If heels cannot fit into the foot unit, adjust the footrest angle to suit the length while moving the reclining seat back or footrest.

■ To extend the foot slide

Press the [EXTEND] button on the remote control after the foot slide automatic adjustment is complete.

■ To shorten the foot slide

Press the [SHORTEN] button on the remote control after the foot slide automatic adjustment is complete.

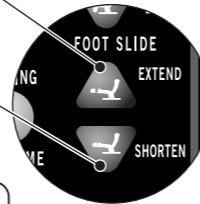
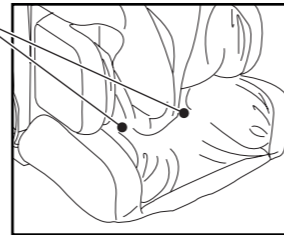

Warning ● Do not place legs or objects between the footrest and the armrest when the foot slide function is in operation.

Headrest

There are 2 headrests in this unit: large and small. These 2 headrests help to stabilize your head in a natural and comfortable position during the massage.

● The smaller headrest's position can be adjusted with the Velcro at the back. Adjust its position to the proper head height before using the chair.

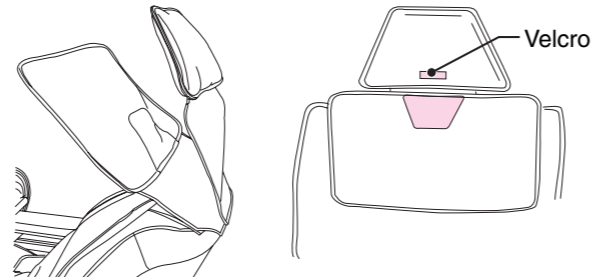

How To Use Buffer Pad

There is a buffer pad located behind the back pad that helps absorb some of the roller stimulation. Remove the buffer pad if you feel that the massage is too light. Replace with thicker accessory buffer pad in the opposite case.

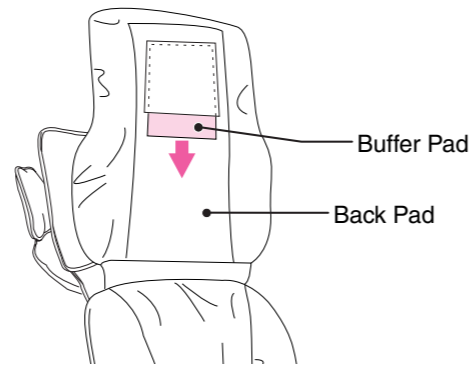

Shiatsu Foot Pad

A Shiatsu Foot Pad is included with this unit. Place on the foot unit if desired.

* Do not use one in the event that the intensity is too high.

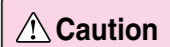

Caution ● If the stimulation is too intense, remove the Shiatsu Foot Pad.

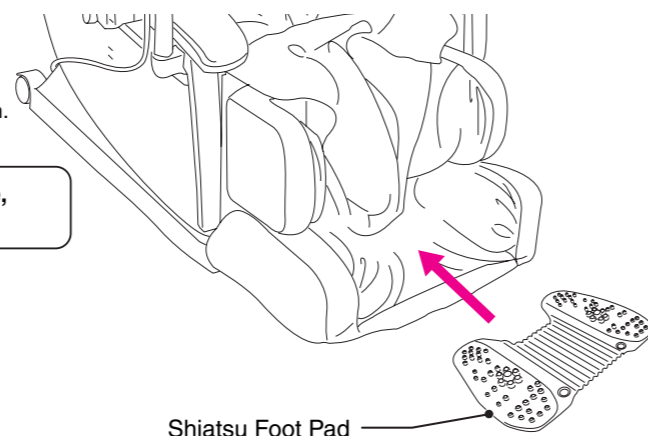

How To Use Lower Arm Units

1. Slide the lower arm units to the desired position before starting a massaging operation.
2. Select a program after fixing the position. Direct your palms downward after letting your arms through.

How to adjust the position of lower arm units

*Push or pull the unit to slide for smooth position adjustment.

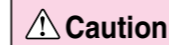
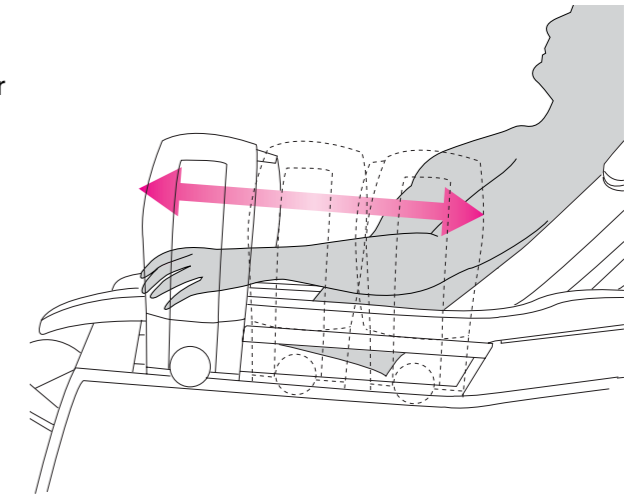
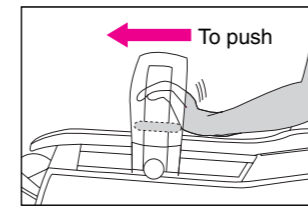
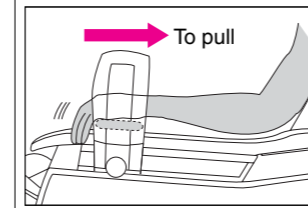

Caution

- Do not wear hard objects like watches, bracelets, or rings when using the unit.
- Do not force your arms back into the lower arm units if they slip out during massaging action. → Undue force may damage the unit.
- Do not apply the lower arm units to any other part of the body than the forearms.

- For safety reasons, both the right and left lower arm units operate alternately. The lower arm unit's positions can be adjusted while stopping the operation underway.
- Do not use these units in an unnatural posture. → May result in injury.

AFTER USE

Return the seat back to its fully upright position and lower the footrest all the way. Then, turn the main POWER switch to OFF before unplugging from the outlet.

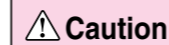

Caution

- Make sure to turn the main POWER switch to OFF after every use and unplug the chair from the wall outlet. → Accident or injury may result if children or pets play with the chair.
- Make sure to return the reclining seat back to the upright position and lower the footrest completely after using the chair.
- Wipe the chair off after every use, and store the chair in a place free of excess humidity.
- Do not pull on the cord to unplug the chair from the wall outlet; be sure to grasp the plug firmly when unplugging.
- If you will not be using the chair for some time, make sure to unplug it from the wall outlet.

MASSAGE PROGRAMS & SELECTION

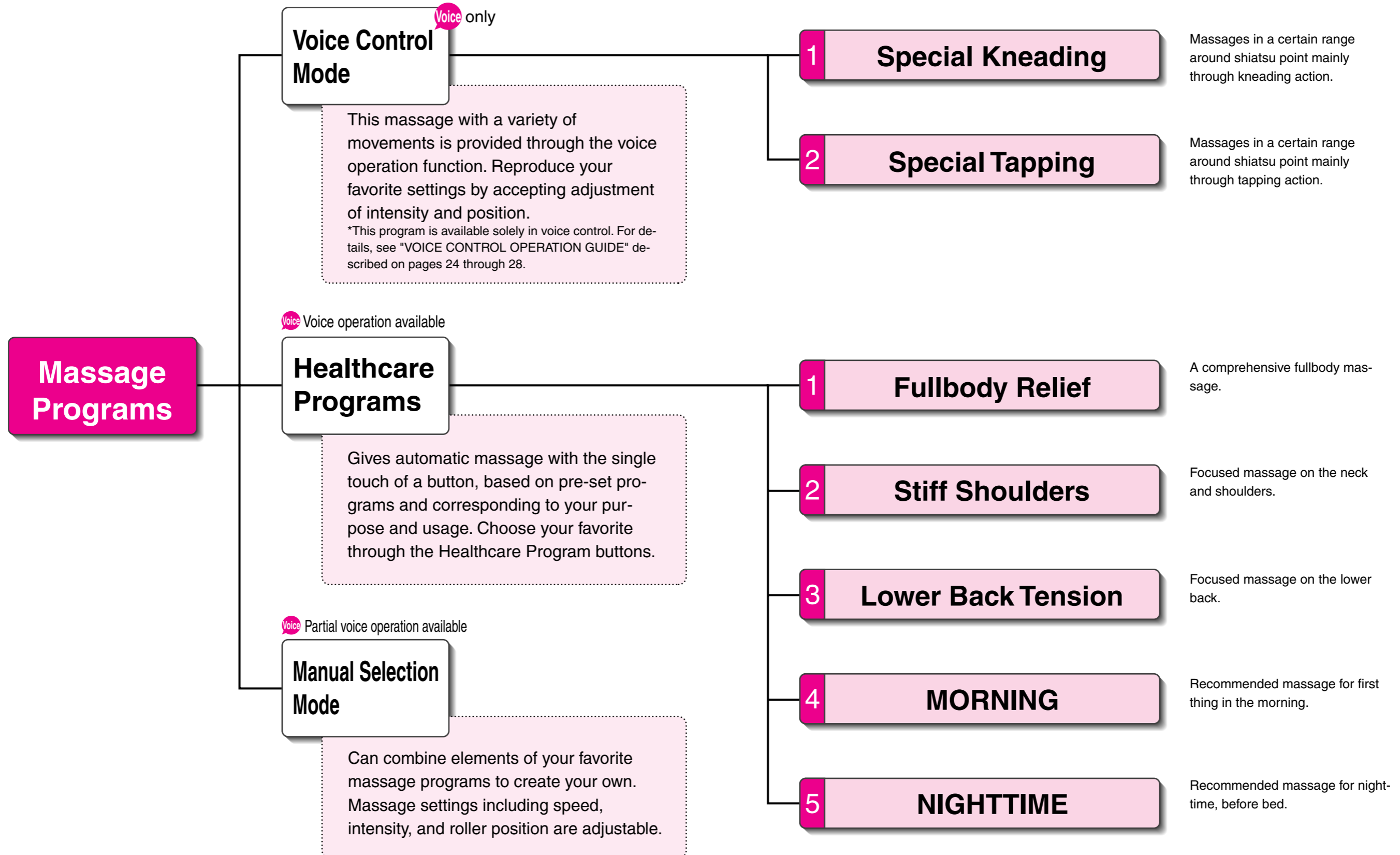

MANUAL SELECTION MODE

Manual Selection Description

You can choose your favorite among: Kneading, Human Hands, Kneading & Tapping, Rhythm Shiatsu 1 or 2, Technique Shiatsu 1 or 2, Tapping 1 or 2, Shoulder Kneading, Roller (Partial or Full), Vibration (Back or Foot), and Air Pressure (Foot, Calf, Seat or Arm). Massage actions including speed, intensity, and roller position are also adjustable.

Basic Massage Actions

Press any one to produce your favorite action. Can be switched to another action just by pressing the corresponding button even during operation.

Action	Display	Description	Action	Display	Description
Kneading		Simple kneading action.	Rhythm Shiatsu		Rhythmical repetitive pressure. Can be switched between 1⇒2⇒Stop in this order through the single touch of the button.
Human Hands		Complex massage action that feels like human hands.	Technique Shiatsu		Reproduces shiatsu close to manual action. Can be switched between 1⇒2⇒Stop in this order through the single touch of the button.
Kneading & Tapping		Kneads and taps at the same time.	Tapping		Tapping action. Can be switched 1⇒2⇒Stop in this order through the single touch of the button.
			Shoulder Kneading		Simple shoulder kneading.

Switching direction Forward and Backward

Action	Display	Action	Display	Description
Forward		Reverse		Can be switched Forward⇒Reverse⇒Stop in this order through the single touch of the button during Kneading, Human Hands, or the Kneading & Tapping massage actions.

Types of Roller Actions

2 types: 3D and 2D Roller are available with which shiatsu points are located automatically like in the Healthcare Program.

Action	2D		3D		Description
	Display	Description	Display	Description	
Full		Up/Down movement only to extend spine.		Up/Down + Front/Back movements to extend spine.	Can be switched between 2D Full⇒3D Full⇒Stop by pressing the button.
Partial		Up/Down movement only to partially extend spine.		Up/Down + Front/Back movements to partially extend spine.	Can be switched between 2D Partial⇒3D Partial⇒Stop by pressing the button.

Air Massage

Can choose your favorite massage action. The intensity can be adjusted with the Air Intensity Adjustment button even during operation.

Action	Display	Description
Foot		Air massage of soles (Display shows [High] pressure.)
Calf		Air massage of calves (Display shows [Middle] pressure.)
Seat		Air massage of buttocks (Display shows [Low] pressure.)
Arm		Air massage of lower arms (Display shows [High] pressure.)

Remote Control Display During Manual Selection Mode

Text or symbols are used to display the type of massage currently selected along with speed, intensity, stroke width, and direction.

Width Adjustment Buttons

Use [NARROW], [MEDIUM], and [WIDE] to adjust the roller position width during Rhythm Shiatsu 1, Technique Shiatsu 1 or 2, Tapping 1 or 2, Full or Partial roller, or Back Vibration. The width can also be changed during massage action.

* Width cannot be altered when a massage that does not accept width adjustment (Kneading, Human Hands, Kneading & Tapping, or Rhythm Shiatsu 2) is combined with Roller or Back Vibration.

Action	Display
Narrow	
Medium	
Wide	

Speed Adjustment Buttons

Use the [FAST] and [SLOW] buttons to adjust the speed of Kneading, Kneading & Tapping, and Tapping 1 in a phases manner during massage. The speed can be changed during massage action.

Action	Display Example	Description
Speed		The display shows that the speed has been set at level 4. ●Speed levels: Kneading6 levels (1 to 6) Kneading & Tapping, Tapping 1 -4 levels (1 to 4)

UP/DOWN Adjustment Buttons

Use the [UP] and [DOWN] buttons during Kneading, Human Hands, Kneading & Tapping, Rhythm Shiatsu 1 or 2, Technique Shiatsu 1 or 2, Tapping 1 or 2, Partial Roller, or Back Vibration to bring the rollers to the area you wish to massage.

*In Partial Roller Massage, the center point for rolling action can be selected with these buttons. When applying Full Roller Massage, these buttons will change the direction of the roller movement.

Action	Button	Description	Action	Button	Description
Up		Rollers move upward.	Down		Rollers move downward.

Vibration Buttons

For vibration in the back or legs. The intensity can be switched between Low⇒High⇒OFF in this order through single touches of the button.

Action	Display Example	Description
Back/Leg Vibration		Vibration massage of back or legs (Turns on and off repeatedly at fixed intervals). (Display shows Back Vibration [High] and Leg Vibration [Low])

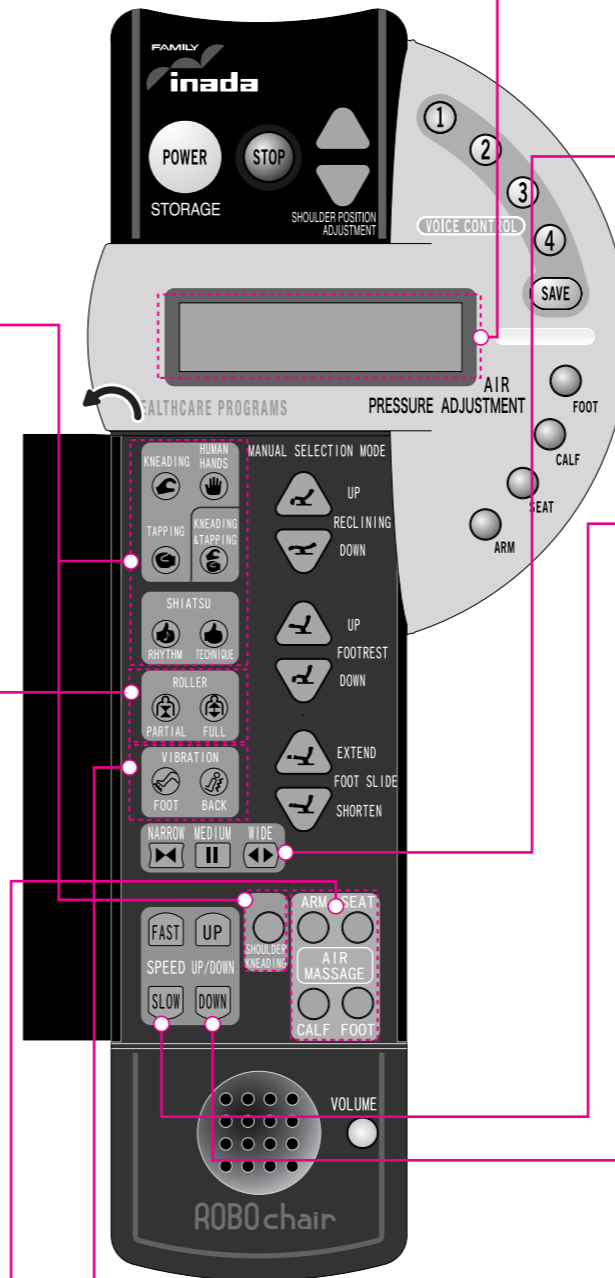

* The remote control is pictured with the panel open.

MANUAL SELECTION MODE

How To Operate Manual Selection Mode

1 Press the [POWER] button.

Open the remote control panel to select the massage type. If no selection is made within 5 minutes, the power automatically shuts off.



2 Press either button to select the preferred massage type.



3 Massage action continues for 15 minutes.

The rollers return to the storage position (upper part of the seat back).

4 Massage has been completed.

Changing Selection

Manual Selection Mode → Healthcare Program

If you press Healthcare Program button during the Manual Selection Mode, the rollers once return to Storage Position before starting the Healthcare Program with the Automatic Shiatsu Point Locator Function.

Stopping In The Middle Of a Massage

To stop in the middle of a massage, press the [POWER] button to bring the rollers back to Storage Position. Then, the massage action stops.

In an emergency or if some malfunction occurs, use the [STOP] button to stop the chair immediately. After a safety check, press the [POWER] button again to bring the rollers back to Storage Position.

Caution

- If you feel the massage is too intense, lower the intensity according to this Operating Manual. If this solution does not work, stop using and contact the vendor. → May result in injury if constantly used on a high stimulation level.
- If your legs or feet come out of the footrest during the massage, do not try to force them back in.
- If your arms come out of the lower arm units during the massage, do not try to force them back in.

Guide To Combining & Adjusting Manual Selection Messages

This guide shows how you can combine massage from the 4 basic menus shown below.

- A circle in the adjustment column means that particular adjustment can be made in the course of the massage.
- When a massage that does not allow width adjustment is combined with a Roller or Back Vibration Massage, the width adjustment function does not activate.
- When Shoulder Kneading or Roller Massage is selected, the Automatic Shiatsu Point Locator function is activated as in the Healthcare Programs.
- Only 2D Roller can be applied along to Manual Shiatsu for both Full and Partial.
- Shoulder Kneading cannot be conducted along with Roller Massage.

1. Basic Massage Actions (Select one from the following 10 types.)	Action	Forward/Backward	Speed	Width (3 levels)	Up/Down <small>Voice</small>	Intensity on back (No level) <small>Voice</small>
	Kneading	○	○6 levels	—	○	○
	Human Hands	○	—	—	○	○
	Tapping 1	—	○4 levels	○	○	○
	Tapping 2	—	—	○	○	○
	Kneading & Tapping	○	○4 levels	—	○	○
	Rhythm Shiatsu 1	—	—	○	○	○
	Rhythm Shiatsu 2	—	—	—	○	○
	Technique Shiatsu 1	—	—	○	○	○
	Technique Shiatsu 2	—	—	○	○	○
Shoulder Kneading	—	—	—	—	○	

+

2. Roller (Choose one from the following 4 types.)	Action	Forward/Backward	Speed	Width (3 levels)	Up/Down <small>Voice</small>	Intensity on back (No level) <small>Voice</small>
	2D Full Spinal	—	—	○	○	○
	3D Full Spinal	—	—	○	○	○
	2D Partial Spinal	—	—	○	○	○
3D Partial Spinal	—	—	○	○	○	

+

3. Vibration	Action	Forward/Backward	Speed	Width (3 levels)	Up/Down <small>Voice</small>	Intensity (2 levels)
	Back Vibration	—	—	○	○	○
Leg Vibration	—	—	—	—	○	

+

4. Air Massage	Action	Forward/Backward	Speed	Width	Up/Down <small>Voice</small>	Intensity (3 levels)
	Arm	—	—	—	—	○
	Seat	—	—	—	—	○
	Calf	—	—	—	—	○
Foot	—	—	—	—	○	

HEALTHCARE PROGRAMS

Healthcare Program Massage

- 5 courses are available to soothe and help improve your overall well-being.
- Performs massages based on pre-set menus with the simple push of a button.

Adjustment Of Massage Action In Healthcare Program

Massage intensity adjustment for back

The rollers push out when [HIGH] is pressed to provide a stronger massage.
The rollers withdraw when [LOW] is pressed to provide a softer massage.

Adjustment of air massage intensity

Pre-set to [Medium] at the initial stage, the intensity can be switched among 3 levels
[Medium]→ [High]→[Low] in this order with the Air Pressure Adjustment button.

Massage cancel

- [LEG]: Omits air massage for legs and buttocks. To restore to normal operation, press this button again.
- [ARM]: Omits lower arm massage. To restore to normal operation, press this button again.
- [BACK]: Omits back massage. To restore to normal operation, press this button again.
* This is to return to the state before the [BACK] button was pressed if no entry is received within 20 seconds after display.
* Once the massage begins, the back massage cannot be regained even if this button is pressed during course operation.



Vibration cancel

Vibration can be omitted as desired by pressing either of the vibration cancel buttons. To restore vibration, press the same button again.



Changing Selection

Healthcare Program → Healthcare Program

If you press any other Healthcare Program button during a Healthcare Program, rollers once return to Storage Position to restart with Automatic Shiatsu Point Locator Function.

Healthcare Program → Manual Selection Mode

If you press a button in the Manual Selection Mode during a Healthcare Program, the program will stop before the manual selection begins.

Stopping In The Middle Of Massage

To stop in the middle of a massage, press the [POWER] button to bring the rollers back to Storage Position. The massage action will stop.

In an emergency or if some malfunction occurs, use the [STOP] button to stop the chair immediately. After a safety check, press the [POWER] button again to bring the rollers back to Storage Position. The previous massage will then stop.



Caution

- If you feel the massage is too intense, lower the intensity according to this Operating Manual. If this solution does not work, stop using and contact the vendor.
→ May result in injury if constantly used on a high stimulation level.
- Do not place hands or feet into the roller tracks, between the seat back and the seat, or into moving parts. Do not wear hard objects like hair accessories, watches, bracelets, or rings while using the chair.
- If your legs or feet come out of the footrest during the massage, do not try to force them back in.
- If your arms come out of the lower arm units during the massage, do not try to force them back in.

Remote Control

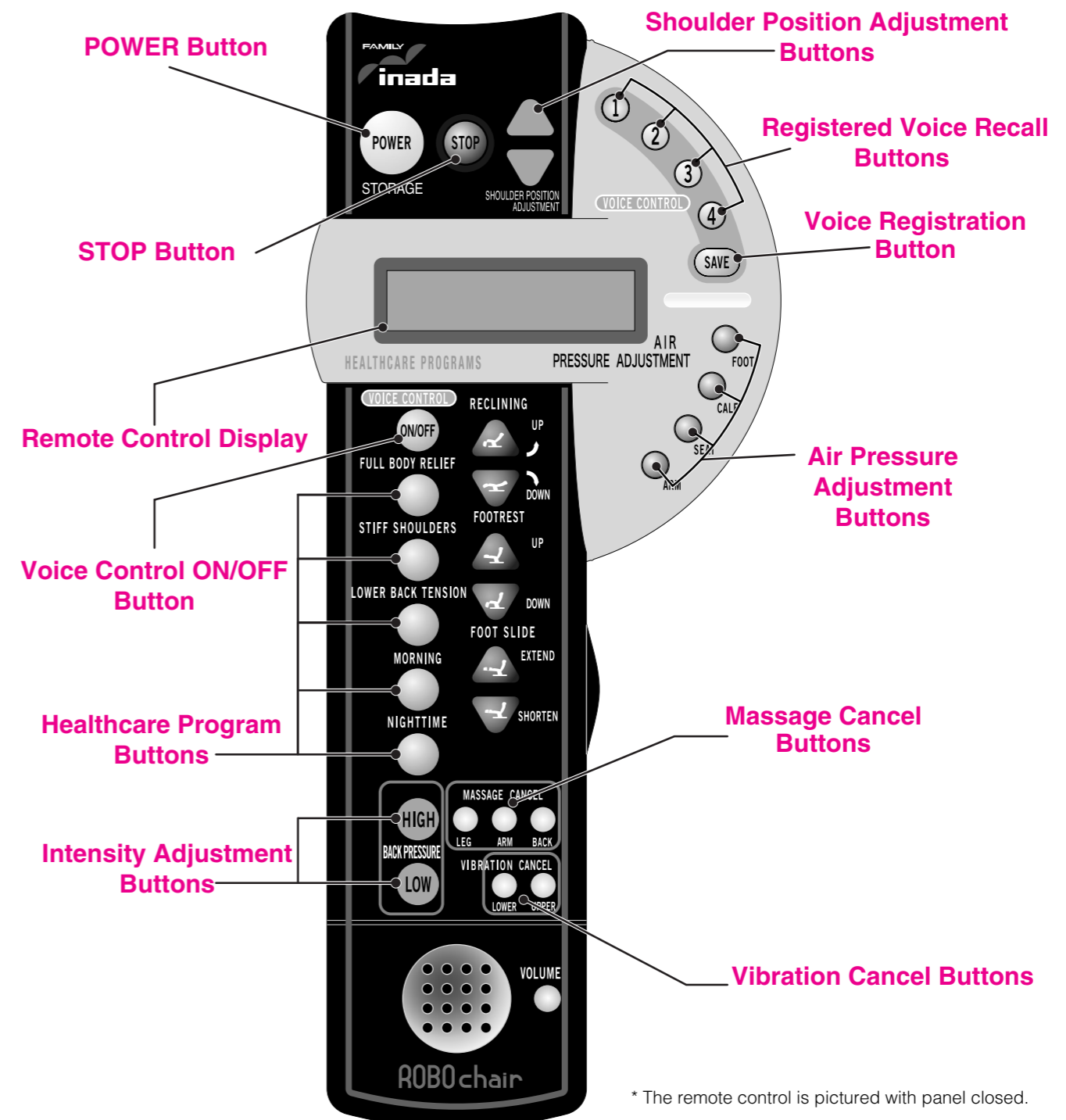

* The remote control is pictured with panel closed.

For operation, see page 23.

SELECTING A HEALTHCARE PROGRAM

- 1 Press the [POWER] button.**
If a Healthcare Program is not selected within 5 minutes, the power will automatically shut off. You are asked to select the program.

 - 2 Adjust the lower arm units to the desired position.**
See page 14 for details.
 - 3 Select your favorite Healthcare button.**
Display shows chosen Healthcare Program.
* Now, Shiatsu Point Locator Function will start. Wait for a moment. Always sit as far back as possible and place your head on the pillow for precise Shiatsu Point.
 - 4 Now, you can adjust the Shoulder Position.**
Use the Shoulder Position Adjustment buttons to raise or lower the roller position. If no adjustment is necessary, just wait for program to start.

 - 5 Place your arms into the lower arm units.**
Arm air massage starts a moment after the program starts.
* Take off hard objects like watches, bracelets, or rings beforehand.
 - 6 Air massage of legs and arms starts.**
 - 7 Massage has completed.**
When massage action is complete, the rollers return to Storage Position (upper part of the seat back).
- Caution**

 - Keep a massage session to no more than 15 minutes in length and Area-Specific Massage of any particular area on the body to no more than 5 minutes.
 - Continual use for extended periods of time can result in over-stimulation, which could cause the opposite of the desired effect, or even injury.
 - Aim for no more than 30 minutes total massage time per day.

VOICE CONTROL OPERATION GUIDE

Pages 24 to 28 give instructions on the voice control function.

Voice Mark

Voice mark can be found alongside several items in this manual. You can operate these items with voice control ON.

Microphone Position

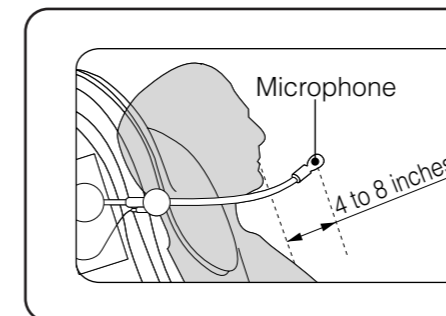

Keep the microphone 4 to 8 inches away from your mouth when using (See the illustration to the left). It is difficult to recognize voiced keywords in the event that the microphone is too close or too far.

Voice Control Unfriendly Condition

Voice control (registration/operation) may not work properly depending on the environment. For example:

- TV or AV equipment set nearby is too loud.
- Conversation or noise nearby is too loud.

In some cases, voice control may fail to function since it has difficulty in identifying voiced keywords under such circumstances. Do not take this as a failure of the product. If this unit is needed to operate in such an environment, use the remote control instead.

HOW TO OPERATE VOICE CONTROL (1) Voice Registration

The voice control can be used without registering your voice. Without voice registration however, the command recognition level will be less effective. This mode stores specified features of a person's pronunciation (for example, intonation) in the memory and will react only to said person's voice.

→ This may not function well if the surrounding environment is noisy and/or there was a problem during registration.

Voice registration is available only when massage action is not being carried on.

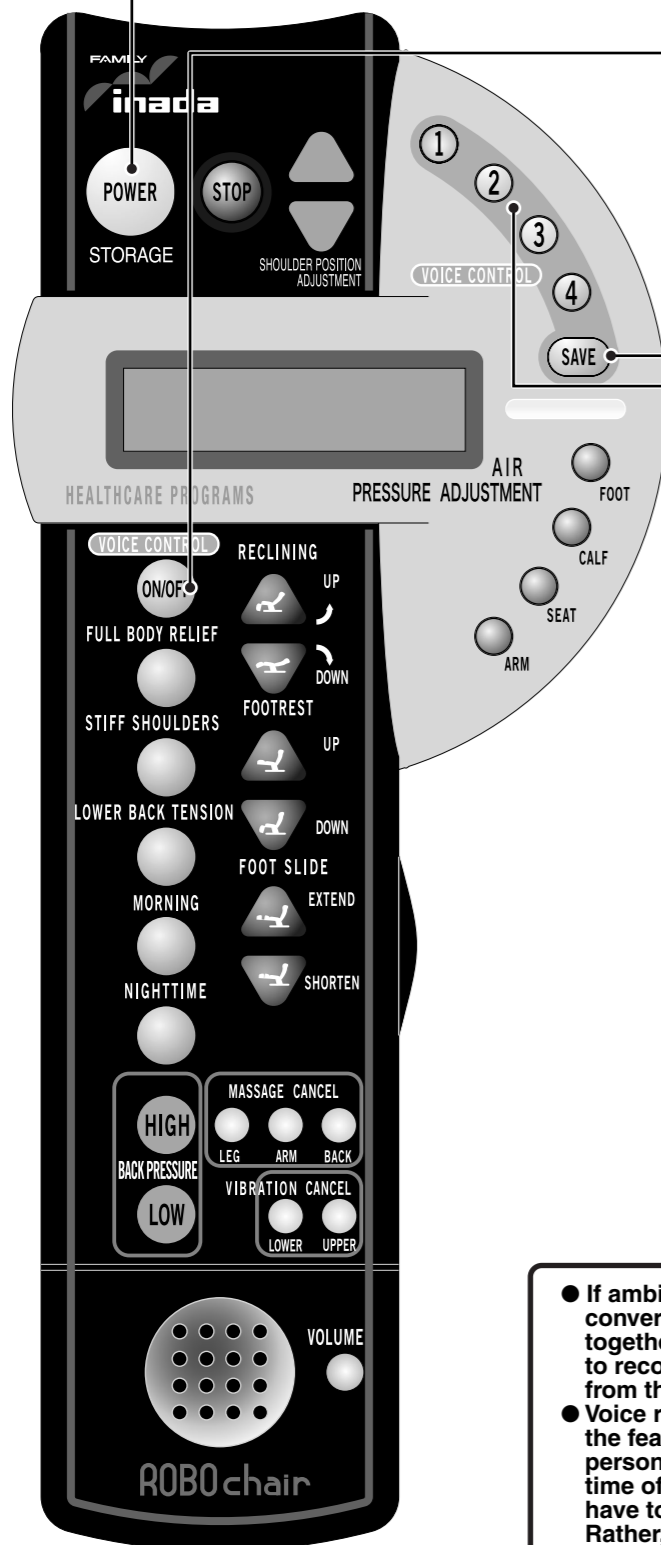

1 Turn on the main POWER switch (back of the chair) and the remote control power.

2 Press the Voice Control ON/OFF button.

"This chair can be operated by your voice. Please pronounce a keyword."

3 Press the Voice Registration button.

4 Press either 1 to 4 to register.

When designating an already-registered number.
A message appears to confirm whether to overwrite or not. If yes, press the same button again. If not, choose a different number button for registration.

5 Voice registration starts.

6 Voice registration is completed.

"The voice registration is complete. The present voice setting is memorized in No. 1 (or No.2 or No.3 or No.4)."

* If voice registration was unsuccessful for the same number 3 consecutive times, the action ends automatically. If overwriting was intended, originally saved data is also lost. In that case, repeat the procedure beginning with step 3 again.

- If ambient condition is noisy with TV, AV equipment, conversation, or other noise, these sounds could be registered together with the necessary keywords or the machine could fail to recognize the voice to register. Start registration procedure from the beginning in as calm a place as possible.
- Voice registration functions to better identify a voice by storing the features of pronunciation (intonation etc.) of a specified person. If the person changes intonation in operating from the time of registration, this does not perform very well. You do not have to match your intonation with any pre-saved guidance. Rather, use your own intonation naturally.

Keywords To Register

Register the following keywords from 1 to 21 after the voiced guidance.

- | | |
|---------------------------|------------------------------|
| 1 Finish | 12 Stiff shoulders |
| 2 Move upright | 13 Lower back tension |
| 3 Recline | 14 Morning |
| 4 Raise footrest | 15 Nighttime |
| 5 Lower footrest | 16 Special kneading |
| 6 Extend | 17 Special tapping |
| 7 Shorten | 18 Arm air |
| 8 Maximum | 19 Lower body air |
| 9 Up | 20 Harder |
| 10 Down | 21 Softer |
| 11 Fullbody relief | |

Ex) **1** To register the keyword "Finish".

1 Massage Chair **2** User

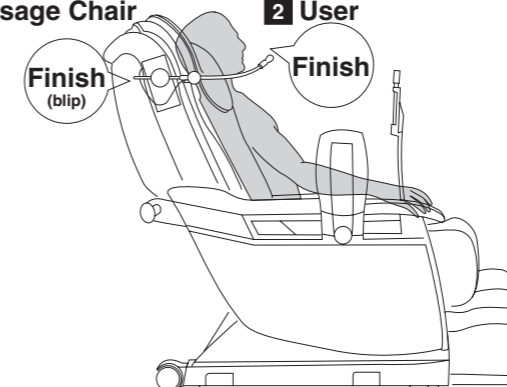

Register the specified keyword with your own voice after hearing the voiced guidance. Do the same way for the other keywords.

HOW TO OPERATE VOICE CONTROL (2) Operation

HOW TO OPERATE VOICE CONTROL (2) Operation



1 Turn on the main POWER switch (back of the chair) and the remote control power.

2 Press the Voice Control ON/OFF button.
"This chair can be operated by your voice. Please pronounce a keyword."

3 Press the Registered Voice Recall button to recall registered voice.
The voice control can be used without registering your voice. Without voice registration however, the command recognition level will be less effective.

4 Say the keyword for the desired function to begin.

■ Volume adjustment for voiced guidance
< Voice control ON >
Switches [Medium] → [High] → [Off] → [Low] → [Medium] → ... in this order every time the Volume button is pressed.
< When voice registration is being performed. >
Switches [Medium] → [High] → [Low] → [Medium] → ... in this order every time the Volume button is pressed. Voice cannot be [Off] in this case.

- If ambient condition is noisy with TV, AV equipment, conversation, or other noise, these sounds could be registered together with the necessary keywords or the machine could fail to recognize the voice to register. Conduct the registration procedure in as calm a place as possible.
- Do not speak with varying stress. Speak clearly while inputting. If a person changes intonation during operating from the time of registration, the specified speaker mode may not perform very well in calling up the registered voice. Input in the same intonation as registered. If the operation is unsuccessful even after doing this, start from voice registration again.
- If the voice operation fails, use the remote control for the same purpose.

Voice Control Keywords

1. Finish	Returns the rollers to Storage Position to switch the remote control OFF.
2. Move upright	Raises the seat back for 7 seconds. Say repeatedly until the desired angle is obtained.
3. Recline	Reclines the seat back for 5 seconds. Say repeatedly until the desired angle is obtained.
4. Raise footrest	Raises the footrest for 7 seconds. Say repeatedly until the desired angle is obtained.
5. Lower footrest	Lowers the footrest for 5 seconds. Say repeatedly until the desired angle is obtained.
6. Extend	Extend the footrest for 0.5 seconds. Say repeatedly until the desired length is obtained.
7. Shorten	Retracts the footrest for 0.5 seconds. Say repeatedly until the desired length is obtained.
8. Maximum	After inputting either "Move upright", "Recline", "Raise footrest", "Lower footrest", "Up" or "Down", record this word within 20 seconds. The maximum state can be obtained without inputting the initial keyword through repeating the above actions.
9. Up	Moves the rollers up.
10. Down	Moves the rollers down.
11. Fullbody relief	Starts the Fullbody Massage after storing the rollers and locating the shoulder position.
12. Stiff shoulders	Starts the Stiff Shoulder massage after storing the rollers and locating the shoulder position.
13. Lower back tension	Starts the Lower Back Tension massage after storing the rollers and locating the shoulder position.
14. Morning	Starts the Morning massage after storing the rollers and locating the shoulder position.
15. Nighttime	Starts the Nighttime massage after storing the rollers and locating the shoulder position.
16. Special kneading	Starts the Kneading program where the rollers move back and forth unlike the Kneading in the Manual Selection Mode. This is initiated after the rollers are returned to Storage Position and the shoulder position is located. The roller position and massage intensity on the back are adjustable (Voice control only).
17. Special tapping	Starts the Tapping program where the rollers move back and forth unlike Tapping in the Manual Selection Mode. This is initiated after the rollers are returned to Storage Position and the shoulder position is located. The roller position and massage intensity on the back can be adjusted (Voice control only).
18. Arm air	Starts air pressure massage of lower arms.
19. Lower body air	Starts air pressure massage of calves, soles, and buttocks.
20. Harder	Strengthens massage intensity by pushing the rollers out.
21. Softer	Softens massage intensity by withdrawing the rollers.

Ex) 1 To register the keyword "Finish".

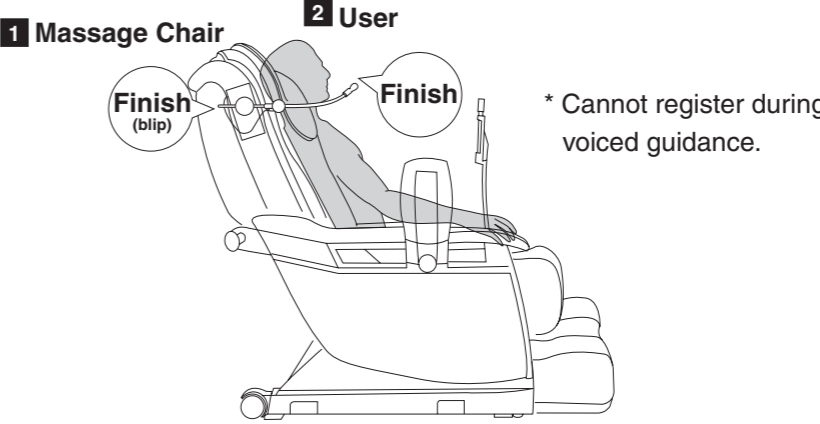

HOW TO OPERATE VOICE CONTROL (2) Operation

TROUBLESHOOTING

Repairs or disassembly may not be performed by anyone other than an authorized serviceperson.

If there is still a problem after trying the solutions given in this troubleshooting guide, stop using the chair immediately so as to prevent accident or injury and unplug the chair from the wall outlet. Contact the vendor for assistance.

Problem	Noise during chair operation: <ul style="list-style-type: none"> ● During Tapping and Kneading & Tapping ● Sound of air pump ● Sound of rollers rubbing against the seat cover ● Vibrating mechanism noise ● Sound of reclining seat back mechanism ● Sound of air massage cushions
Cause & Solution	These noises are a normal part of the chair's operation and do not affect its performance in any way.
Problem	Remote control buttons do not seem to be activating normally.
Cause & Solution	Check for the following possible problems: <ol style="list-style-type: none"> 1) Is the power cord fully plugged into the wall outlet? 2) Is the power cord fully plugged into the connector at the back of the chair? 3) Is the main POWER switch in back of the chair set to ON?
Problem	Remote control display shows the message, "Restart the main POWER switch."
Cause & Solution	Turn the main POWER switch on the back of the chair to OFF, wait 5 seconds and then turn it ON again. <ol style="list-style-type: none"> 1) If the chair returns to normal, no further action is needed. 2) Check to be sure that the footrest connector is fully attached. 3) If the same message is displayed again, stop using the chair and unplug it from the wall outlet. Contact the vendor for assistance.
Problem	The Automatic Shiatsu Point Locator Function is not working properly (The height of rollers does not fit the shoulders).
Cause & Solution	Sit further back in the chair so your head rests firmly on the seat back. Or, you can adjust the shoulder position with the Shoulder Position button just after the Shiatsu points are located. (This Automatic Shiatsu Point Locator Function does not activate in a Manual Selection Massage except for Shoulder Kneading, and Full/Partial roller.)
Problem	The footrest adjusting function is not working properly (The footrest does not reach the bottom of my feet).
Cause & Solution	Sit with your ankles touching the back of the foot unit so that the sensors (located near the ankle) can function properly. If your ankles do not reach the back of the foot unit, use the footrest buttons to adjust the angle. See page 13 for details.

TROUBLESHOOTING

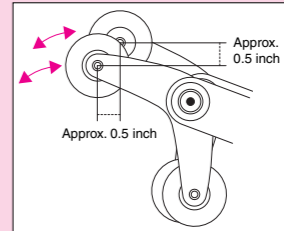
Problem	Massage action stops in the middle of the program.
Cause & Solution	Turn the main POWER switch on the back of the chair to OFF. Wait 5 seconds and then turn it ON again. <ol style="list-style-type: none"> 1) If chair returns to normal, no further action is needed. 2) If this doesn't fix the problem, stop using the chair immediately to prevent any accident or injury. Unplug the chair from the wall outlet and contact the vendor for assistance.
Problem	The rollers stop during the massage.
Cause & Solution	Sometimes when the massage speed is slow and there is too much pressure on the rollers, they can stop moving temporarily. This is not breakage. Just slightly lift your body.
Problem	The rollers moved up to the top and then stopped.
Cause & Solution	The auto timer will cause the rollers to move up to the top of the chair when the massage time is finished, so as not to interfere with your movements when getting out of the chair. If you want to continue the massage, press the POWER button on the remote control again.
Problem	The right and left rollers are out of alignment.
Cause & Solution	The rollers are designed to provide for the alternating tapping function, so in the stopped position they are sometimes out of line -- this is part of their design and there is nothing wrong with the chair. 
Problem	The lower arm units do not work.
Cause & Solution	Check whether the lower arm units have been correctly installed. If they do not start even after checking, disassemble in the reverse order of assembly. Then, install again from the start.
Problem	If I try to raise or lower the footrest or use the Foot Slide function during the leg or foot massage, the chair stops.
Cause & Solution	For safety purposes, the air pressure massage is designed to stop if the footrest or foot slide is activated during the massage.
Problem	The reclining function does not work.
Cause & Solution	Check if there is anything caught between reclining seat back and control box, or armrest and side cover. The reclining safety unit may have been activated.

TROUBLESHOOTING

TROUBLESHOOTING

Problem

Voice registration does not work well.

Cause & Solution

Check for following possible problems:

- 1) Is the plug of the microphone unit correctly inserted?
- 2) Is the distance between your mouth and the microphone appropriate? Is it too close?
Keep the distance from approx. 4 to 8 inches.
- 3) Your voice may not register and/or be recognized due to surrounding noise like TV, AV equipment, conversation, or other noise. Try registration in as calm a condition as possible.
- 4) Register within 3 seconds after the blip following the voiced guidance.
- 5) Use a clear voice without varying stress for best registration.

Problem

Voice cannot be recognized well.

Cause & Solution

Check for following possible problems:

- 1) Is the plug of the microphone unit correctly inserted?
- 2) Is the distance between your mouth and the microphone appropriate? Is it too close?
Keep the distance from approx. 4 to 8 inches.
- 3) Your voice may not register and/or be recognized due to surrounding noise like TV, AV equipment, conversation, or other noise. Try registration in as calm a condition as possible.
- 4) Use a clear voice without varying stress in inputting keywords.
- 5) Input the next keyword after a short interval for consecutive recording.

When operating with voice unregistered (Unspecified speaker mode)

- Check whether the input keyword is correct (See page 28).

When operating with registered voice (Specified speaker mode)

- Be sure that the correct Registered Voice Recall button is selected. If you mistakenly choose any other button except for the one with registered voice, press the Voice Control ON/OFF button to switch the voice control OFF. Then, press it again before selecting the appropriate button with your registered voice.

Re-register your voice if any one of following cases is applicable:

- Have you used different intonation for keywords in operation from that of initial registration?
→ Voice registration enables identification of your voice by comparing with the features of pronunciation of the recorded voice. If both vary, this function may not work well.
- Have you used different keywords from those registered?
→ If so, there is no way for voice function to recognize what is being said.

FAQ

Q

The panel on the remote control came off. Can it be reattached?

A

The panel on the remote control comes off to prevent damage if the lid is opened forcefully. It is not breakage. Just press it back into place.

Q

How do I make a massage deeper?

A

Use the Intensity Adjustment buttons if you are operating with the remote control, and say "High" if you are operating through voice control. Should you feel it is too low even after the above procedure, rest your weight against the seat back by reclining seat back and sitting more deeply. You can also intensify by removing the buffer pad from inside the back pad.

Q

How do I make the massage lighter?

A

Use the Intensity Adjustment buttons if you are operating with the remote control, and say "Low" if you are operating through voice control. Should you feel it is too high even after the above procedure, replace the buffer pad inside the back pad with the thicker accessory pad. You can also lighten the pressure by raising the seat back.

Q

I spilled water on the chair. What should I do?

A

Immediately turn the main POWER switch OFF and unplug the power cord from the wall outlet. Contact the vendor for assistance.

Q

Can I use the chair even if overweight?

A

We recommend the chair to be used by people weighing up to 220 lbs. If you weigh more than that, try sitting lightly in the chair without leaning too hard on the seat back.

CARE & STORAGE

Storage

- After wiping off any dust or dirt, store your chair in a place that is relatively dry.
- If you are not going to use the chair for some time, put a cover on it that will protect it from dust and dirt.
- Pets can sometimes chew on power cords, so try to keep pets away from the chair even when it's being stored.

Caution ● Do not install the chair where it can come into contact with direct sunlight or heat like near a heater.

Cleaning

Caution ● Be sure to unplug the power cord from the outlet before cleaning. Do not plug/unplug the power cord with wet hands.

[Back pad, Headrest, and Chair covering]

First, soak a soft cloth in lukewarm water and a little amount of neutral detergent. Then, wring it out thoroughly before wiping.

Caution ● Do not leave the chair in contact with vinyl or wallcovering for a long time. This will cause decolorization of the chair.

[Remote control, Control box, Microphone/Speaker, and Microphone attachment unit]

Use a dry cloth to wipe.

- Never use a wet towel for these parts. → May result in failure.

[Other plastic parts]

First, soak a soft cloth in lukewarm water and a little amount of neutral detergent. Then, wring it out thoroughly before wiping. Finally, use a dry cloth to remove any adhering detergent.

- Do not use alcohol, other types of solution, or abrasive powders for cleaning, since the chair parts may get scratched, discolored, or may crack.

Removing Headrest & Back Pad

Follow these instructions when removing the headrest and back pad.

* To put them back on, follow these instructions in reverse.

1. Undo the Velcro that holds the headrest in place on the back pad and remove the headrest.
2. Undo the zipper that holds the back pad and remove it.

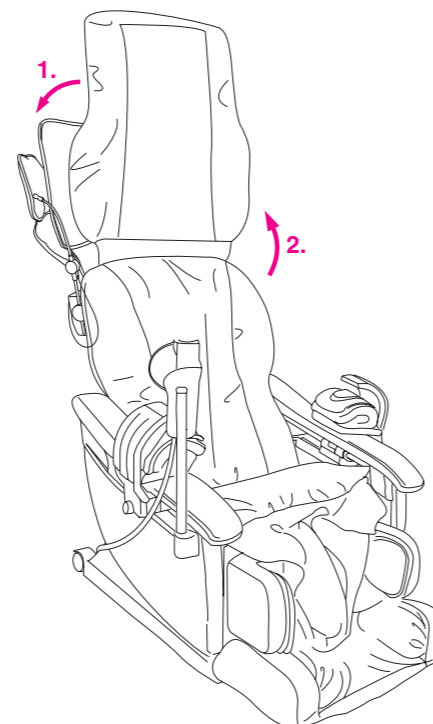

CUSTOMER SERVICE & WARRANTY

1. WARRANTY

A warranty card is provided separately by each vendor.

Please read the contents carefully and keep it in a safe place. (You will need the card to facilitate warranty repairs.)

If the chair is to be used outside the home (in a commercial setting, for example), fees will be charged for repairs even while the chair is under warranty.

2. REPAIRS & SERVICE

Before calling for repairs or service, use the Troubleshooting guide on pages 29-31 to see if the problem can be solved easily.

If the problem persists, contact the vendor for assistance.

Have the following information ready.

- 1) Your name, address, and phone number
- 2) Product name and model number (see the back page of this manual)
- 3) Serial No. (see the Serial No. label on the back cover of the chair)
- 4) Date of purchase
- 5) Trouble status
- 6) Proof of purchase

● If the warranty is valid:

Show the vendor the warranty card.

A service charge may apply, subject to the nature of the trouble and/or repair according to the terms of the warranty. See the warranty for full details.

● If the warranty has expired:

Consult the vendor.

If the product can be repaired, the vendor will give you an estimate of the cost to repair the product.

● Replacement parts stock:

We will stock service parts (except fabric) of this product for at least six years after terminating the production of this model. Service parts refer to those necessary for maintaining the intended performance of the product.

● For more information on service:

Contact the vendor.

REGULAR MAINTENANCE FOR SAFETY

Regular Maintenance Will Preserve the Life of Your Chair.

Have you experienced any of these problems?

- The chair does not start with the main power switch set to on.
- The power cord has been cracked or scratched.
- The power cord or plug becomes abnormally hot.
- The chair produces a burnt smell, abnormal sound or vibration.
- The auto timer function does not work in some cases.
- The fabric is torn where it comes into contact with the rollers or air cells.
- Other failures.

If you find anything listed above, stop using and unplug the power cord from the outlet to prevent failure or accident. Be sure to contact with the vendor for maintenance.

To Use Safely

* Durability varies depending on condition of use.

* After about five years of use, a professional inspection is recommended even if there are no symptoms or problems.

For inspection fees, contact the vendor.